

REVISION HISTORY		
REV	DATE	ECN
		17-0554
		22-0654

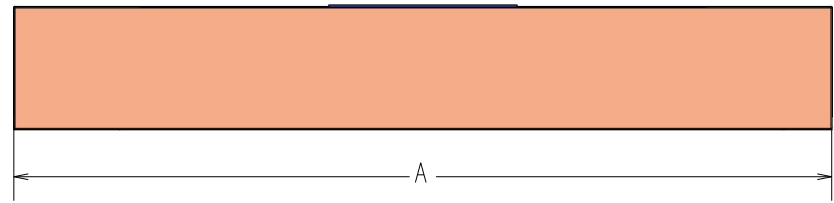

**TOP VIEW**

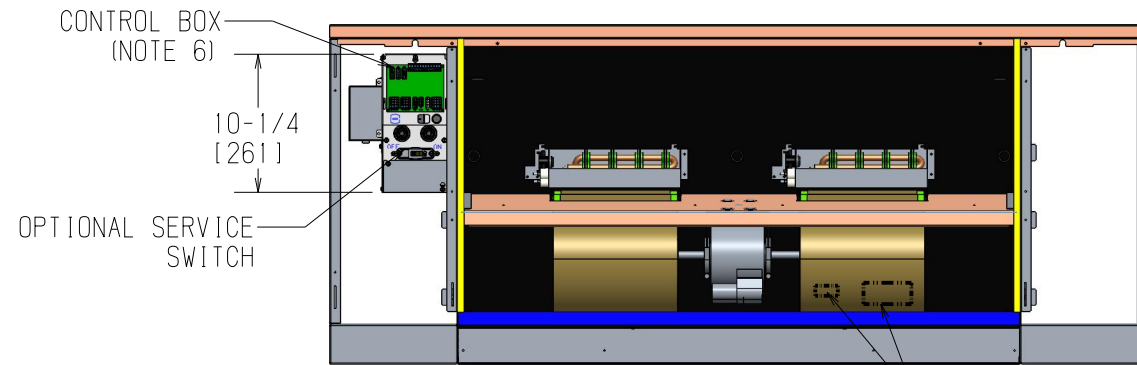

**FRONT VIEW  
(WITHOUT ACCESS PANEL)**

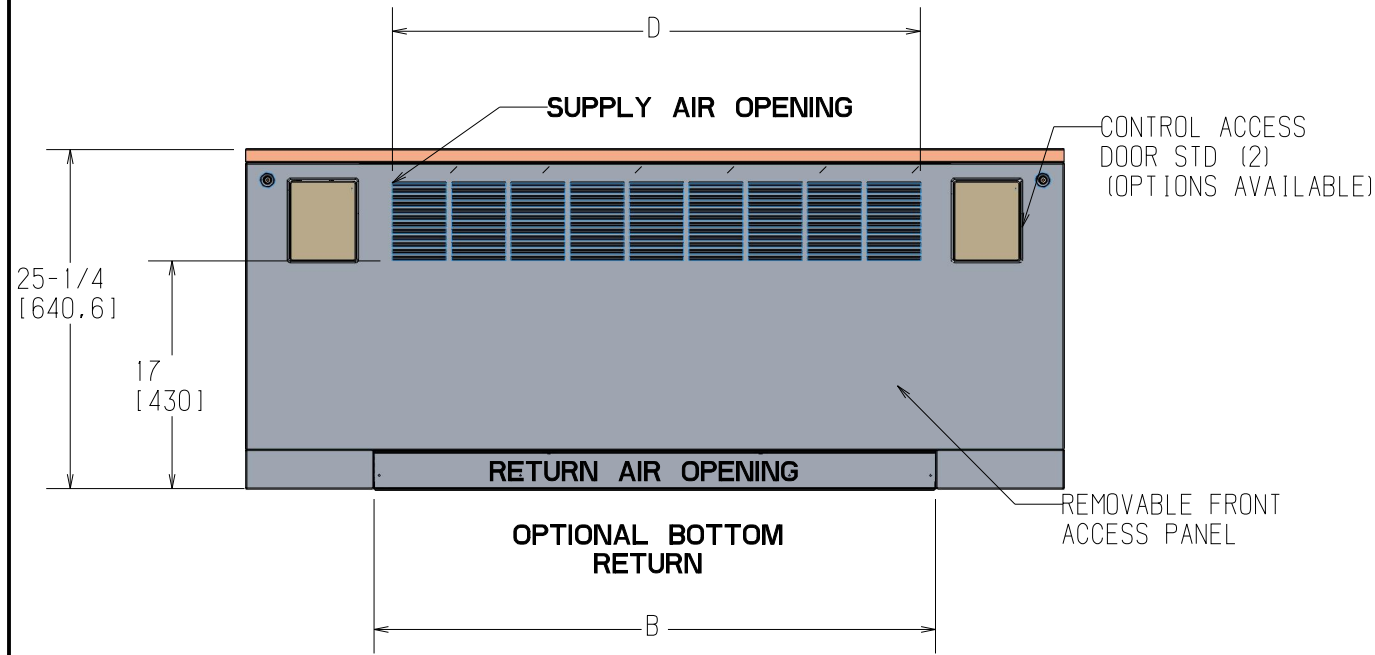

**FRONT VIEW**

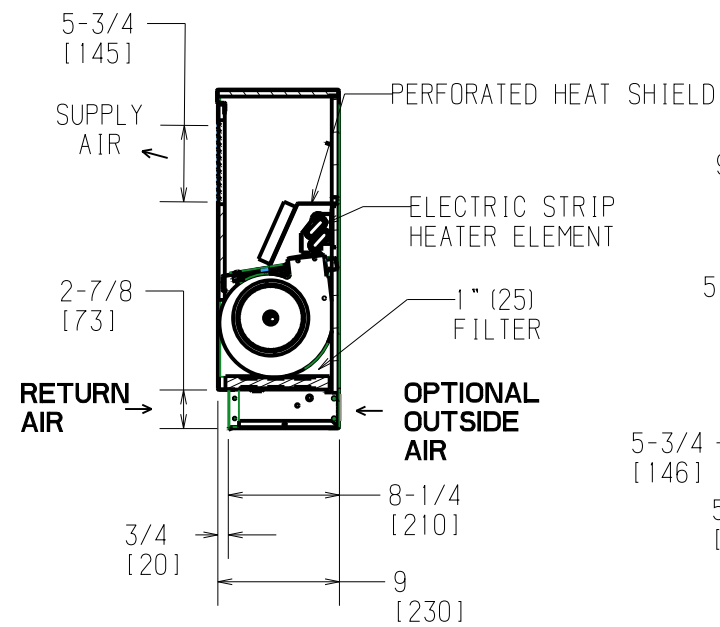

**RIGHT SIDE VIEW**

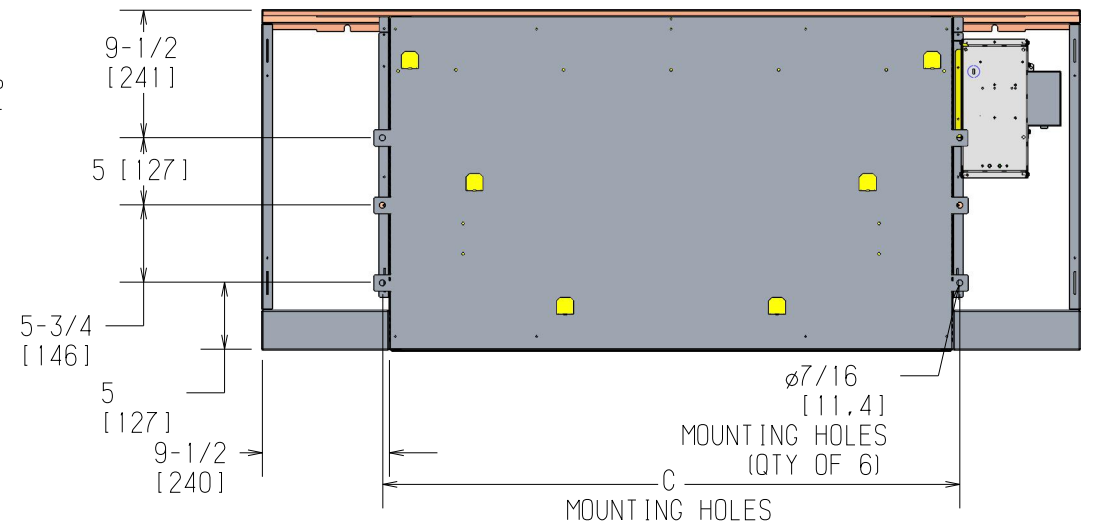

**REAR MOUNTING VIEW**

- NOTES:
1. LH CONTROLS SHOWN. RH OPPOSITE.
  2. ALL DIMENSIONS ARE +/- .25 (6). DRAWING NOT TO SCALE.
  3. PRODUCT SPECIFICATIONS ARE SUBJECT TO CHANGE WITHOUT NOTICE.
  4. CONTROL BOX SIZE AND POSITION MAY VARY (CONSULT FACTORY)
  5. POSITION MAY VARY.
  6. SERVICE ACCESS IS LOCATED ON THE FRONT OF THE CONTROL BOX.
  7. KNOCKOUTS ON THE BOTTOM AND SIDE OF THE CONTROL BOX FOR INCOMING POWER CONNECTIONS

Unit Model	Dimensions - Inches (Millimeters)				Quantity/Unit	
	A	B	C	D	BLWR	MOTOR
GXY 02	41 (1041)	22 (559)	23 (584)	17-1/4 (438)	1	1
GXY 03	45 (1143)	26 (660)	27 (686)	21-1/2 (546)	1	1
GXY 04	51 (1295)	32 (813)	33 (838)	26 (660)	2	1
GXY 06	61 (1549)	42 (1067)	43 (1092)	39-1/4 (997)	2	1
GXY 08	63 (1600)	44 (1118)	45 (1143)	39-1/4 (997)	2	1
GXY 10	77 (1956)	58 (1473)	59 (1499)	52-1/2 (1334)	4	2
GXY 12	85 (2159)	66 (1676)	67 (1702)	61-1/4 (1556)	4	2



<b>TITLE</b> VERT CUH CABINET FRNT SPLY (GXY) ELEC HEAT			
<b>DWG NO</b>			<b>PCV</b>
<b>DRAWN</b>	<b>DATE</b>	<b>APPROVED</b>	<b>DATE</b>