

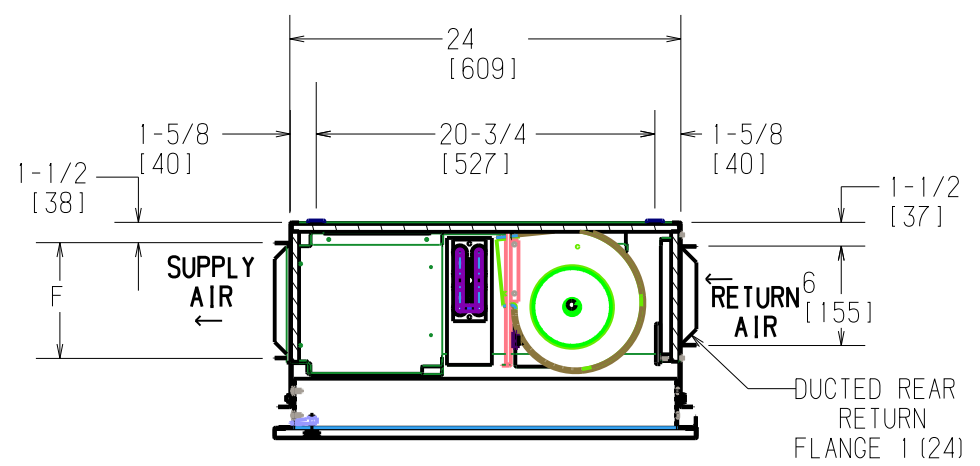

REVISION HISTORY		
REV	DATE	ECN
-		21-0151

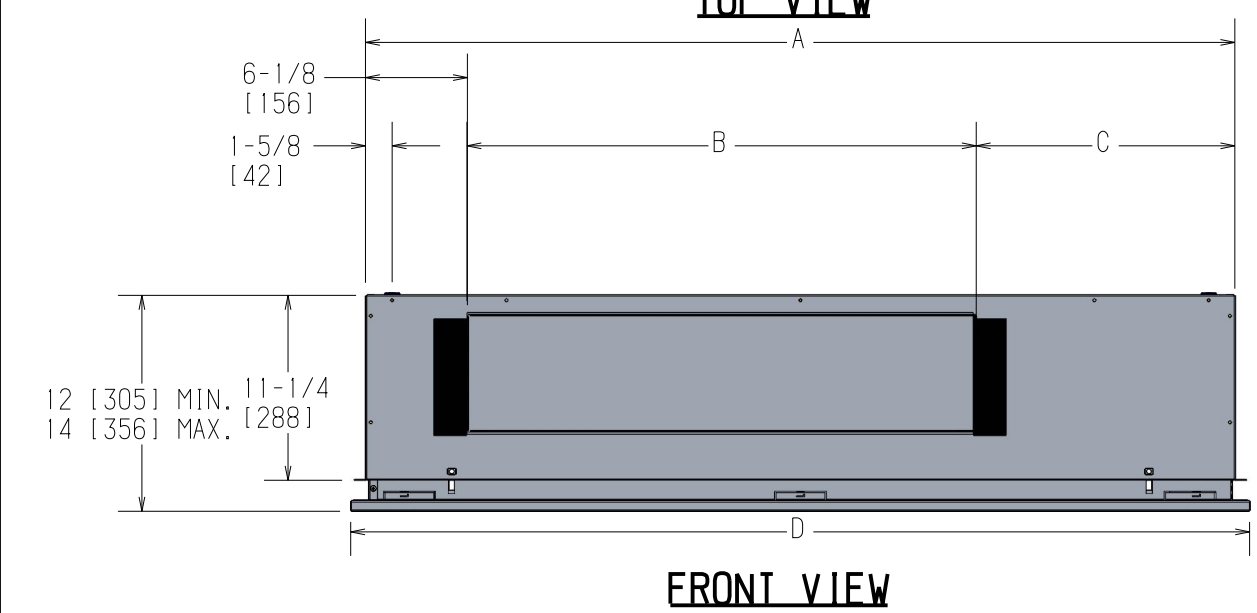
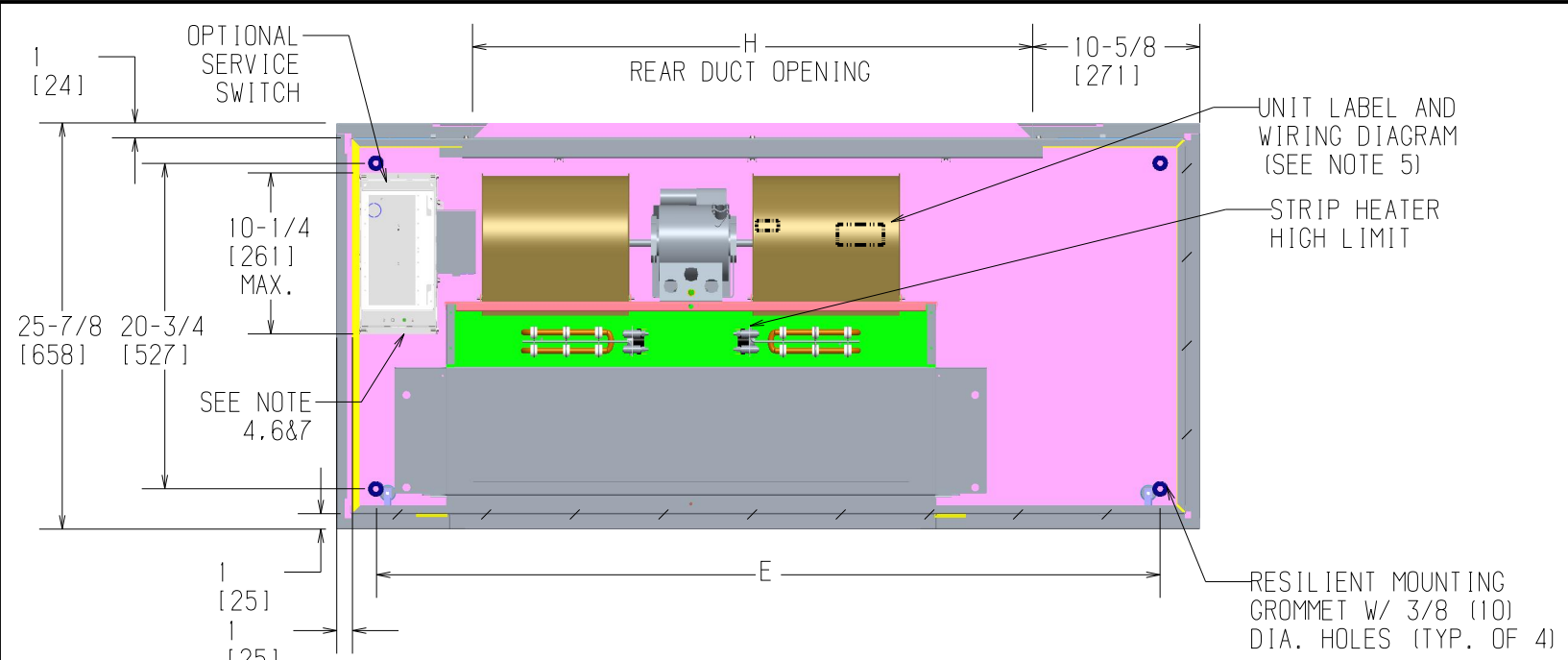

- NOTES:
1. RH SHOWN, LH OPPOSITE.
  2. ALL DIMENSIONS ARE +/- .25 (6) . DRAWING NOT TO SCALE.
  3. PRODUCT SPECIFICATIONS ARE SUBJECT TO CHANGE WITHOUT NOTICE.
  4. CONTROL BOX SIZE AND POSITION MAY VARY (CONSULT FACTORY)
  5. POSITION MAY VARY.
  6. SERVICE ACCESS IS LOCATED ON THE FRONT OF THE CONTROL BOX.
  7. KNOCKOUTS ON THE BOTTOM AND SIDE OF THE CONTROL BOX FOR INCOMING POWER CONNECTIONS
  8. TYPICAL SIZE 06 UNIT SHOWN WITH 1-MOTOR AND 2-BLWR - REFER TO TABLE FOR VARIATION.
  9. SEE VALVE PACKAGE SUPPLEMENTAL FOR PIPING TERMINATION.
  10. FIELD CONNECTION PIPES WILL BE SHIPPED LOOSE WITH VALVE PACKAGES.

Unit Model	Dimensions - Inches (Millimeters)							Quantity/Unit	
	A	B	C	D	E	F	H	BLWR	MOTOR
DBY 02	35 (889)	16 (406)	12-3/4 (324)	37 (940)	32 (813)	6 (152)	18-3/4 (476)	1	1
DBY 03	35 (889)	20 (508)	8-3/4 (225)	37 (940)	32 (813)	6 (152)	18-3/4 (476)	1	1
DBY 04	41 (1041)	26 (660)	8-3/4 (225)	43 (1092)	38 (965)	6 (152)	24-3/4 (629)	2	1
DBY 06	53 (1346)	31 (787)	15-3/4 (400)	55 (1397)	50 (1270)	7 (179)	35-3/4 (908)	2	1
DBY 08	53 (1346)	38 (965)	8-3/4 (225)	55 (1397)	50 (1270)	7 (179)	35-3/4 (908)	2	1
DBY 10	75 (1905)	52 (1321)	16-3/4 (425)	77 (1956)	72 (1829)	7 (179)	49-3/4 (1264)	4	2
DBY 12	75 (1905)	60 (1524)	8-3/4 (225)	77 (1956)	72 (1829)	7 (179)	49-3/4 (1264)	4	2



**TITLE** DBY HORZ TELESCOPING CABINET HEATER  
ELEC HEAT

DWC NO		REV	
DRAWN	DATE	APPROVED	DATE